

Q PHONE USER GUIDE

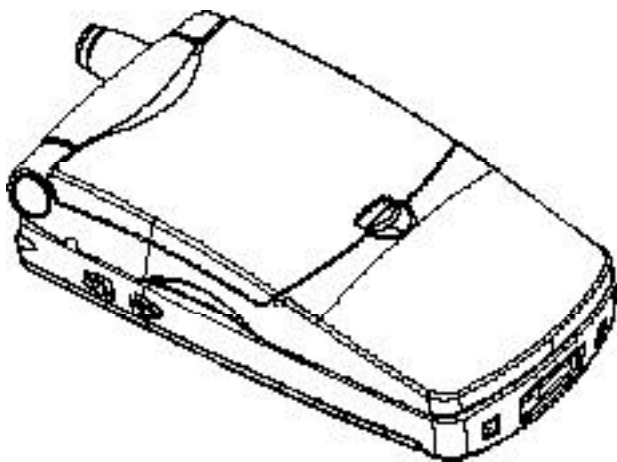

Kyocera Wireless Corp.
10300 Campus Point Drive
<http://www.kyocera-wireless.com>

80-B6670-1, Rev. -

This manual is based on the production version of the Q phone. Software changes may have occurred after this printing.

The products and equipment described in this documentation are manufactured under license from QUALCOMM Incorporated under one or more of the following U.S.

Patents:

4,901,307,	5,056,109,	5,099,204,	5,101,501,
5,103,459,	5,107,225,	5,109,390,	5,193,094,
5,228,054,	5,257,283,	5,265,119,	5,267,261,
5,267,262,	5,280,472,	5,283,536,	5,289,527,
5,307,405,	5,309,474,	5,337,338,	5,339,046,
5,341,456,	5,383,219,	5,392,287,	5,396,516,
D356,560,	5,408,697,	5,414,728,	5,414,796,
5,416,797,	5,426,392,	5,437,055,	D361,065,
5,442,322,	5,442,627,	5,452,473,	5,461,639,
5,469,115,	5,469,471,	5,471,497,	5,475,870,
5,479,475,	5,483,696,	5,485,486,	5,487,175,
5,490,165,	5,497,395,	5,499,280,	5,504,773,
5,506,865,	5,509,015,	5,509,035,	5,511,067,
5,511,073,	5,513,176,	5,515,177,	5,517,323,
5,519,761,	5,528,593,	5,530,928,	5,533,011,
5,535,239,	5,539,531,	5,544,196,	5,544,223,
5,546,459,	5,548,812,	5,559,881,	5,559,865,
5,561,618,	5,564,083,	5,566,000,	5,566,206,
5,566,357,	5,568,483,	5,574,773,	5,574,987,
D375,740,	5,576,662,	5,577,022,	5,577,265,
D375,937,	5,588,043,	D376,804,	5,589,756,
5,590,069,	5,590,406,	5,590,408,	5,592,548,
5,594,718,	5,596,570,	5,600,754,	5,602,834,
5,602,833,	5,603,096,	5,604,730,	5,604,459,
5,604,730,	5,608,722,	5,614,806,	5,617,060,
5,621,752	5,621,784,	5,621,853	5,625,876,
5,627,857,	5,629,955,	5,629,975	

Other patents pending.

Copyright © 2000 Kyocera Wireless Corp.

All rights reserved. Portions of this document are

Copyright © 1997 by QUALCOMM Incorporated.

CONTENTS

Contents	3
Important Information	5
Highlights.....	6
Clamshell Design	7
Display Indicators.....	10
Using the Battery	11
Turning the Phone On and Off	12
Antenna	13
Charging the Battery.....	13
Basic Functions	15
Function Keys	15
Making a Call.....	16
Correcting Dialing Mistakes	16
Getting Your Own Phone Number.....	16
Receiving Calls.....	17
Call Waiting	17
Three-way Calling	18
Redialing Calls.....	18
Adjusting Volume	18
Emergency Dialing	18
Signal Strength.....	19
Power Save Mode.....	20
Phone Book Feature	21
The Two Phone Book Types	21
Saving Numbers to Your Primary Phone Book.....	22
Retrieving Numbers from your Phone Book	23
Changing Your Phone Book	26
Dialing Numbers from Your Phone Book	27
Advanced Phone Book Features	28
Menu Feature	31
Main Menu	31

Menu Access Method	31
Shortcut Menu Access Method.....	32
Menu Item Descriptions	32
Paging, Messaging, and Voice Mail.....	39
New Message Alert	40
Viewing Pages and Messages.....	41
Voice Mail Notifications	43
Low Memory Warning	44
Out of Memory Warning.....	44
Accessories	45
Phone Safety and Care	46
Background	46
For Best Performance.....	47
Antenna Care.....	47
Caring for the Battery	48
Driving Safety	49
Other Safety Guidelines	50
Where To Find Help.....	53
Your Service Provider.....	53
Your Phone Documentation	53
Kyocera Technical Support	53
Index	55

Important Information

Caution

The user is cautioned that changes or modifications not expressly approved by the party responsible for compliance could void the warranty and the user's authority to operate the equipment.

Warning

Use only Kyocera Wireless Corp. approved accessories with Kyocera Wireless Corp. phones. Use of any unauthorized accessories may be dangerous and will invalidate the warranty if said accessories cause damage or a defect to the phone.

FCC/IC Notice

This device complies with part 15 of the FCC Rules. Operation is subject to the following two conditions: (1) This device may not cause harmful interference, and (2) this device must accept any interference received, including interference that may cause undesired operation.

GETTING STARTED

Highlights

Congratulations on your purchase of the Q phone. It is an easy-to-use, versatile, and dependable palm-sized phone which provides many unique features including:

- Large, easy-to-read, 4-line backlit text display with an additional line for informative icons
- 19-button lighted keypad
- Menu-driven interaction with prompts
- Inherent call privacy through CDMA encoding
- Clamshell design that opens for placing/receiving calls and closes for minimum size, maximum portability, and keypad locking
- Any key answer, speed dial, auto redial, and 99 memory locations for phone numbers
- Advanced features such as short messaging service and caller ID
- Selectable ringer, including a built in vibrator
- Optional accessories

This section includes drawings of the important phone parts and instructions on getting your phone powered up and ready to use.

Clamshell Design





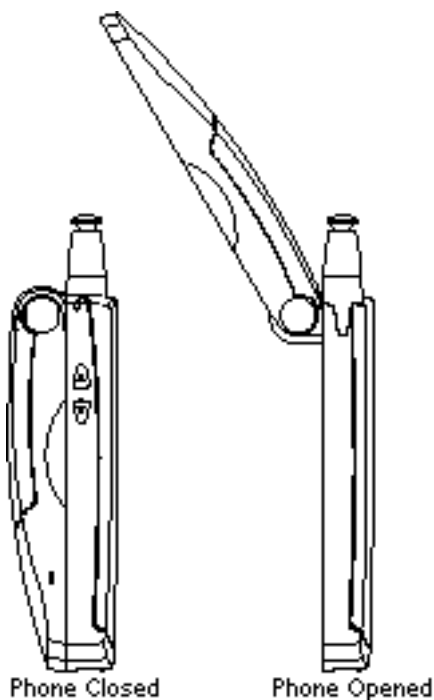

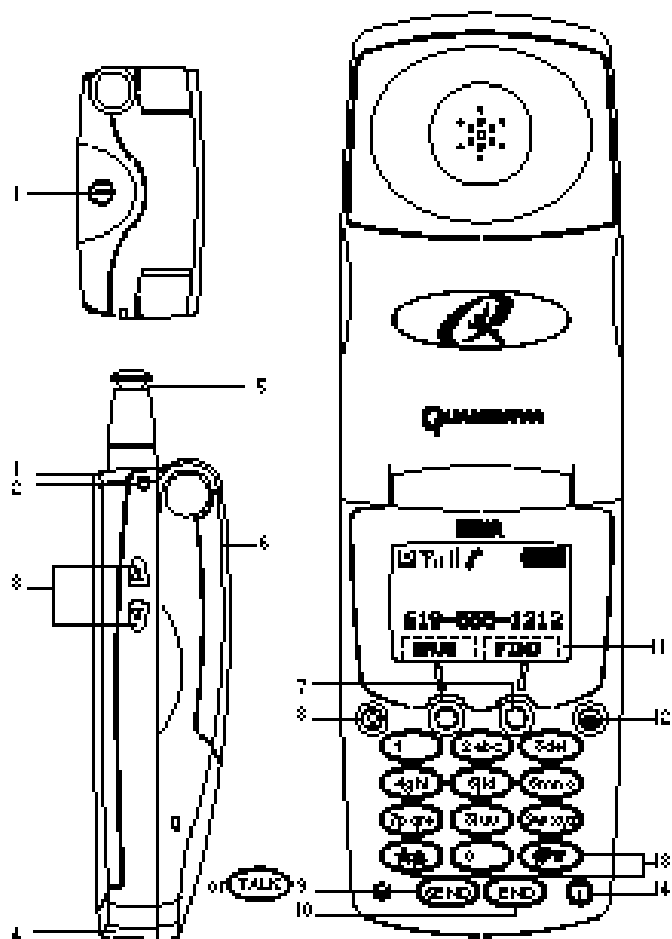

The phone opens and closes like a clam shell. It must be open to use any of the phone's features. When the phone is closed, the keypad is locked and covered. You will hear the phone ring (if the phone is on) but you must open the phone to answer the call.

This feature allows you to keep the phone on, and in your pocket or brief case, without accidentally pressing any keys. Since the power  button is on the outside of the phone, the phone can be turned on or off whether the phone is open or closed.



Front, Side, and Top Views of the Phone









- 1  **Power** turns power on and off (phone may be open or closed).
- 2 **Light** lights red when phone is powered on or off and when there are incoming calls and messages.
- 3 **Volume/Scroll Keys** let you adjust the volume and scroll through the menus.
- 4 **Data Connector** provides connection to the car kit and other accessories.
- 5 **Antenna** provides best voice quality when all the way up.
- 6 **Battery** provides power to the phone.
- 7 **Smart Keys** are used in context with the text display. The current operation of a Smart Key is defined by the word above it on the display.
- 8  **Clear** clears the digits and/or text from the display.
- 9  places and receives calls and activates network features (i.e. call waiting and three-way calling).
- 10  disconnects a call and/or returns to standby display.
- 11 **Smart Keys Name Indicator** border and word that defines the current operation of the Smart Key .
- 12  **Envelope** allows quick access to text and voice mail notification messages.
- 13  or  allow you to scroll through the menu options and displays.
- 14  **Info** shows your phone's number, provides additional information about the call record, and for added functionality.

Display Indicators

Display indicators are located at the top of the display. Different indicators appear based on the phone's operating mode.



-  **Digital Indicator** Indicates that you are receiving a digital signal.
-  **Signal** Indicates current signal strength. More lines means better signal strength.
-  **No Service** The phone is not receiving a signal from the system.
-  **In Use** The call is in progress.
- No Icon** The phone is in standby.
-  **Roaming** The phone is outside of its home area.
-  **Message Received** There is a text message, voice notification, or page waiting.
-  **Battery** Indicates battery charge level status. The more black you see the greater the charge.

Using the Battery

The phone comes with a rechargeable battery pack. The battery pack is shipped with approximately 50% capacity so you can use it immediately after purchasing the phone. Remember to keep your battery charged in order to maximize the talk time and standby time.

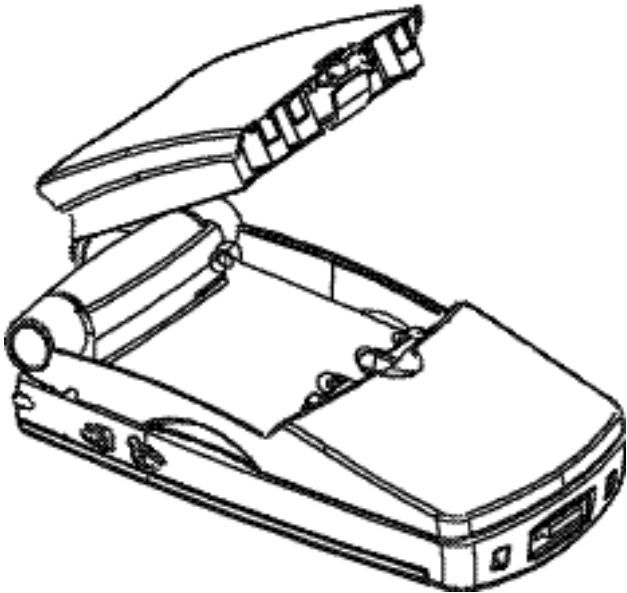

Removing and Installing the Battery

To remove the battery:

Press down on the battery release latch and simultaneously lift the battery up and out of the phone.



To install the battery:

Place the battery into the opening at a 45° angle and rotate the battery down until the latch clicks.





Turning the Phone On and Off

Turning On

Make sure that the charged battery pack has been installed in the back of the phone or that you have external power (using the cigarette lighter adaptor or car kit).

Press the  button until the red light is lit. If the phone is closed, the  button must be held for approximately 3 seconds. If the phone is open, the  button must be held for 1 second.

Turning Off

1. Press the  button until “Powering Off” is displayed or until the red light flashes. If the phone is closed, the  button must be pressed for approximately 3 seconds. If the phone is open, the  button must be held for 1 second.
2. Release the  button.

When the power is off, nothing displays on the screen.

Note

If the  button is pressed for less than 1 second when open or 3 seconds when closed, the phone will not turn off.

Antenna

Raise the antenna for best voice quality.

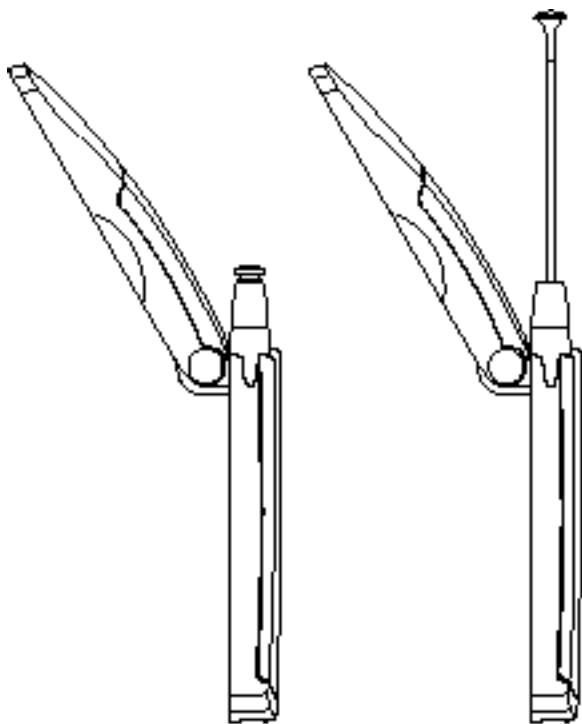

Antenna Down

Antenna Up

Charging the Battery

The battery charge level is shown at the top right of the display when the phone is open.



When the battery charge level becomes low, the low battery sensor will alert you by displaying the screen icon and sounding an audible tone. If the battery level becomes too low, the phone will switch off and any function in progress will not be saved.

Batteries may be charged using the standard desktop charger, optional travel charger, or cigarette lighter adaptor.

Using the Desktop Charger

Warning: Only use the desktop charger and AC adaptor provided with the phone. Using the wrong adaptor may cause damage.

1. Plug one end of the AC adaptor into the charger holder and the other end into a wall outlet.
2. Insert the battery pack in the rear of the charger or the phone with installed battery pack into the front of the charger or both simultaneously. You should then see a red light on the charger indicating that the battery is being charged.

If completely discharged, the battery will charge in approximately 1 to 2 hours. If you leave the phone on while it is in the desktop charger, the battery will take longer to charge.

You do not need to completely discharge the battery before charging. Unlike other battery systems, there is no memory effect which could degrade the battery's performance.

BASIC FUNCTIONS

Function Keys

The following keys perform these functions when pressed during most procedures:

 Clears characters from the screen. Press once to erase one digit or character. Press and hold to erase all digits. When in a menu, press once to go back one level or press and hold to go back to the standby display.

 Disconnects a call. Also exits all the way out of a menu back to the phone's most basic standby display without changing the setting.

 Provides hyphens, and hard or timed pauses when programming a number in memory; accesses special characters when in text mode; and also provides additional information and functions.

 Places a call.

 Left and right Smart Keys below the display select whatever option is directly above them.

 Scrolls through phone book entries and menu items.

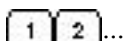
 ... Enters numbers and characters, and chooses menu items.

Making a Call

First, check that your phone is on. The display indicators should be visible on the screen.

1. Open the phone.
2. Enter the phone number.
3. Press **SEND/TALK**. If the phone is locked, the number is restricted, or there is another problem, you will see a help message.
4. Press **END** or close the phone to disconnect the call.

Correcting Dialing Mistakes

Press **C** to erase one digit at a time. Press and hold **C** for at least one second to delete all digits or letters.

Getting Your Own Phone Number

If your phone has been activated, you can see your phone's number by doing the following:

1. Turn the phone on. Open the phone if it is closed.
2. Press **I**.

Receiving Calls

Your phone must be powered on to receive calls. The phone may be open or closed.

If the phone is open:

Press any key (except the  button or the volume keys) to answer.

If the phone is closed:

Open the phone (unless the “Call Answer” feature is set to “by keypress” for caller ID purposes).

To disconnect the call:



Press  or close the phone.

To silence the ringer when the phone is closed:

If you choose not to answer an incoming call or just want to silence the ringer, press the  button for less than 1 second.

Call Waiting

Your service provider may offer call waiting. When you are in a call, you may hear two beeps indicating another incoming call.

1. Press  to access this call.
2. Press  again to toggle between the two callers.

Three-way Calling

Your service provider may offer three-way calling.

1. Press **SEND/TALK** to connect the three parties.
See your service provider for more instructions.

Redialing Calls

Redialing Last Outgoing Number

1. Press **SEND/TALK** to redial the last outgoing call.

Redial Last Ten Calls

You can redial any of your last ten calls through the call history list. See the **Phone Book** section.

Adjusting Volume

The volume keys on the side of the phone can be used for three different functions:

- Adjusting earpiece volume when you are in a call
- Adjusting ringer volume when the phone is not in use
- Scrolling through menu items when you are using the menus or phone book features
- The **[M]** button can be used to silence the ringer (or deactivate the vibrator) when you need to silence an incoming call alert.

Emergency Dialing

You can place calls to 911 or one of the other three emergency numbers that are in your phone book even if your phone is locked or restricted. The service provider may have preprogrammed the three emergency numbers for you.

Making Emergency Calls

1. Press **9** **1** **1** or one of the other three emergency numbers.
2. Press **SEND/TALK**.

Saving and Editing Emergency Numbers

1. Press the **□** key under [MENU].
2. Press **3** for Security menu.
3. Enter the lock code. The lock code is typically set to either 0000 or to the last four digits of the phone's number.
4. Press **4** for Emergency #.
5. Press the **□** key under [EDIT] to make changes to the first emergency number.

or

Press the **□** key under [NEXT] to see the next emergency number.

Signal Strength

The quality of the call depends on the signal strength in your area. The phone displays the current strength as a number of bars next to the signal strength icon; the more bars, the better the signal.



If the signal is poor, raise the antenna all the way for best performance. If you are in a building, the reception may be better near a window.

Power Save Mode

The power save mode feature will automatically turn on if the phone has not been able to acquire any systems after 15 minutes of searching. While this feature is active, the phone's battery charge is conserved. The phone will automatically recheck for service periodically. To manually force the phone to recheck for service, press any key. A message on the display will indicate when the phone is operating in power save mode.

PHONE BOOK FEATURE

The Two Phone Book Types

You should be familiar with the basic functions of the phone before using the phone book. There are two types of phone books: primary phone book memory and recent call history list.

Primary Phone Book Memory

The phone has 99 general use phone book memory locations where you can store entries of up to 32 digits with an associated name up to 12 characters.

Recent Call History List

The phone keeps a list of the last 10 non-repeated calls you made, accepted, missed, or added.

Depending on the operating mode and available features, each entry may contain the phone number, name, and time stamp (which indicates when the call occurred).

You may see one of the following entries:

- | | |
|------------------|---|
| MISSED | Indicates an unanswered incoming call if caller ID is available. |
| CALLED BY | Indicates a call you received and answered if caller ID is available. |
| CALL TO | Indicates a call you placed. |
| ADDED | Indicates that the number was added using the scratch pad feature. |

- While viewing a call history entry, press **(i)** to show additional information available such as the time stamp.

Saving Numbers to Your Primary Phone Book

Memory locations 1 to 9 should be used for one-touch dial or most commonly used phone numbers.

1. Enter the phone number that you want to save. [SAVE] will then appear.

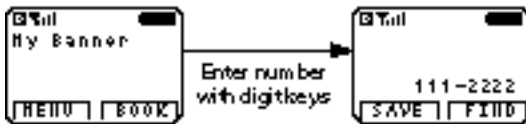

2. Press the **(□)** key under [SAVE].
3. Enter a name to go with the number.

Press the key labeled with the letter you want. Press it once to get the first letter on the key, twice to get the second, three times to get the third, and four times for the number (or fourth letter). If you miss the letter you want, keep pressing the key until it reappears. Press **(C)** to correct any mistakes. Two seconds after you choose a character, the cursor moves to the right one character. Repeat this process until the name is entered.



4. Press the **(□)** key under [OK] to save the name and move to the next step.

5. Press the  key under [OK] to store the number in the first available storage location.

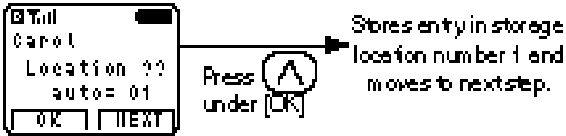

or

Enter a specific, two digit location number.

6. Press the  key under [OK] to save the number.

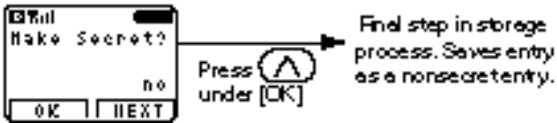

or



Press the  key under [NEXT] and then the key under [OK] to save the number as secret. (Secret numbers do not display on the screen.)

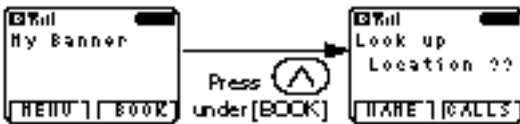

Retrieving Numbers from your Phone Book

Press the  key under [BOOK] to access the phone book.





Retrieving all Manually Stored Memory Locations



1. Press the  key under [BOOK].
2. Press  or  or the volume keys to scroll through the memory list.

3. Press the  key under [VIEW] to see what is in that memory location.
4. Press the  key under [ERASE] or [EDIT] or press  to call.



Retrieving One Entry by Memory Location Number

1. Press the  key under [BOOK].
2. Enter the two digit memory location number. You will then see what is in that memory location.
3. If occupied,  to call or press the  key under [ERASE] or [EDIT].

Retrieving by Name Search

1. Press the  key under [BOOK].
2. Press the  key under [NAME].
3. Enter the letter(s) that you want to look for.
4. Press the  key under [FIND].





The phone then searches for names with those letters. You will see a list of matches.

5. Press  or  or the volume keys to scroll through the list.
6. Press the  key under [VIEW].

or

Press  to call.

Retrieving Recent Call History

1. Press the  key under [BOOK].
2. Press the  key under [CALLS].
3. Press  or  or the volume keys to scroll through the last ten calls.
4. Press  to place a call.
or

Press the  key under [VIEW] to see specifics of the call.





5. Press the  key under [SAVE] to save the number to a memory location.

If the number already has a name associated with it, it is already entered into a memory location.

While viewing an entry, press  to show additional information available such as the time/date stamp.



Retrieving by Part of Phone Number Search

You can look for a phone number if you know at least three of the digits.









1. Enter any three sequential digits from the phone number on the main screen..
2. Press the  key under [FIND].
3. If there is a match, press  or  or the volume keys to scroll to desired entry.
4. Press the  key under [VIEW] to see the entry or  to place a call.

Changing Your Phone Book

Erasing a Stored Memory

1. Press the  key under [BOOK]. Recall and view the memory location.
2. Press the  key under [ERASE]. This will erase the name and number from the memory location leaving it free for a future entry.
3. Press the  key under [OK].
4. “-erased-” will flash on the display to confirm that the entry has been erased.

Editing a Stored Memory Location

1. Recall the memory location.
2. Press the  key under [EDIT].
3. Edit the number using the digit keys, and .
4. Press the  key under [OK].
5. Edit the name using  or , the digit keys, and .
6. Press the  key under [OK]. You are then prompted for a memory location.
7. Press the  key under [OK] to use the memory location listed or enter a new memory location.
8. Press the  key under [OK] to finish the editing process and store as a nonsecret entry.

Dialing Numbers from Your Phone Book

You can make a call using any memory location either by speed dialing from the list or by pressing **SEND/TALK** while viewing the full contents of the memory location.

Speed Dialing

You can quickly dial numbers that are saved in your phone's phone book.

1. Press the key(s) that correspond to the numeric memory location. Example: for memory location 10, press the key under [BOOK], and then press **1** **0**.
2. Press **SEND/TALK**. The phone will find the telephone number in its phone book, display it on the screen, and then dial it.

One-touch Dialing

One-touch dialing enables you to dial phone book entries through one key press (for locations 1 to 9) or two key presses (for locations 10 to 99).

You can turn one-touch dialing on through the "One-Touch" item under the "Features" menu.





For memory locations 1 to 9:

Press and hold the appropriate key for at least one second.



For locations 10 to 99:

1. Press the first digit.
2. Press and hold the key for the second digit.

Dialing from a Memory List

1. Press the  key under [BOOK].
2. Press  or  to go to the memory location you want.
3. Press .

Dialing from within a Memory Location

While viewing any memory location, press 
.



Advanced Phone Book Features

Pause Feature

When you call automated systems (such as voice mail or credit card billing numbers), you often have to enter a series of numbers. Instead of entering the numbers by hand, you can store the numbers in your phone book separated by special characters called pauses. There are two kinds of pauses:

- **Hard Pauses**— You have to press the  key under [RESUME] to go to the next number.
- **Timed Pauses**—The phone will send the next set of numbers after two seconds. Each additional timed pause will add two more seconds to the pause length.

Storing a Number with Pauses

1. Enter the number.
2. Press .
3. Press  for HardPause.

or

Press **[2]** for TimePause.

4. Enter additional numbers (i.e., pin number, credit card number).
5. Press the **[OK]** key under [SAVE].

Note

You can press **[3]** for Hyphens. Hyphens are used for appearance only; the phone dials the number without any delays.

Punctuation Characters for Name Entry

You can use any of the 18 special characters while you are entering names during phone book storage or editing.

1. Press **[1]** during the “Enter Name” step.

You will then see a list of characters.

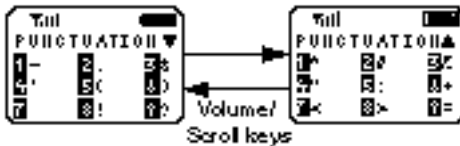

2. Press the **[Left Arrow]** or **[Right Arrow]** to see the other nine characters that you may choose from.
3. Press the number next to the character that you want.
4. Continue entering the name.

Case Changing During Name Entry



When entering a name, you can use both upper and lower case letters.

1. Press the  key under [A->a] to change case.
2. Enter letters.

“Prepending” a Stored Number

“Prepend” is used if you are out of your home system and need to add the area code to an existing phone book entry, call history entry, or messages callback number shows up on the display, you can make additions to the beginning of the original number. However, you can’t edit the original number during “prepend.”

To “prepend” a number:

1. Recall a number in memory.
2. Press any digits. Digits entered will prepend the recalled number.
3. Press   to dial the new, longer number.

Making an Entry Secret

You can set memory locations to “secret” (which hides the phone number and only displays the name). If you do not enter a name to go with the number, you will see the word “secret” in any memory displays or lists. “Secret” memory locations can only be deleted, not edited.

MENU FEATURE





Main Menu

This section describes the various menu items. An arrow to the right of the title indicates if there is more information before () or after () that particular number. The main menu looks like the following:







Menus allow you to check or change the phone's various features and settings. You may see the different menus using either the menu access method or the shortcut menu access method.

Menu Access Method

1. Press the  key under [MENU].
2. Press  or  to step forward or backward through the list of features.
3. Press  to go back one step.
4. Press the number corresponding to the menu item that you want to select.
5. Press the  key under [NEXT].

or

Press  or  to cycle through the possible settings. A check mark indicates the current option selection.

6. Press the  key under [OK] to save the setting.
7. Press  to cancel without saving.

Shortcut Menu Access Method

Each menu feature can also be quickly accessed by pressing the key under [MENU] and the numbers on the desired menu screen. For example, when the shortcut is used, the phone displays the current menu item setting.



Menu Item Descriptions

1 Vibrate



This feature allows you to change the alert during an incoming call. If set to “on” then the phone will vibrate when a call is first received. Additionally, if the ringer is also on then the phone will ring after vibration stops.



2 Volume

This allows you to adjust the ringer, key beep, and earpiece volume.

- | | |
|----------|--|
| 1 Ringer | Adjust ringer and new message alert volume with the  or  keys or volume keys. You can also adjust the ringer volume by pressing the volume keys on the side of the phone |
|----------|--|

only while the phone is in standby or is ringing. Possible settings: silent, escalating, low, M-, M+, high. Escalating means that the ringer volume will get progressively louder with each ring.

2 Key Beep Adjust the key beep volume (the sound the phone makes when the keys are pressed with the  or  keys or volume keys). Possible settings: silent, low, M-, M+, high.

3 Earpiece Adjust the earpiece volume with the  or  keys or volume keys. You can also adjust this during a call by pressing only the volume keys. Possible settings: low, M-, M+, high.

3 Call Info

This allows you to see the number and duration of various kinds of calls.

- 1 Last Call Display duration of last call in minutes and seconds.
- 2 Home Calls Display the total number of calls and time (minutes and seconds), of all calls made while in the home system (i.e., not roaming), since last reset. Press the  key under [ZERO] to reset.

- 3 Roam Calls Display the total number of calls and time (minutes and seconds) of all calls made while roaming. Press the key under [ZERO] to reset.
- 4 All Calls Display the total number of calls and time (minutes and seconds) including calls made while in the home system and while roaming. This is NOT resettable.

4 Security

You must enter the lock code to see what is in the security menu. Typical default values are either the last 4 digits of your phone number or 0000.

- 1 Lock Mode Choose when you want the phone to lock. Possible settings: “on power up,” “now,” “never.” “Now” immediately locks the phone. When the lock code is entered, this is reset to “never.” “On power up” locks the phone when the phone is turned on. “Never” means that the phone is never locked. When locked, you can only make emergency calls or receive incoming calls. All other functions of the phone are disabled. If you forget your lock code, please call your service provider for help.

- 2 Restrict Set phone use restrictions to “yes” or “no.” If set to “yes,” you can only make calls to emergency numbers and phone numbers in locations 1 to 9.
- 3 New Code Enter a new four digit lock code number.
- 4 Emergency# Enter three emergency numbers. You can call these numbers and 911 even when the phone is locked or restricted. If dialing the number, it must exactly match one of these programmed numbers for it to override the lock and restriction settings.
- 5 Clear Calls Clear the call history information.

5 Features

- 1 Call Answer Select how a call is answered. Allows you to answer a call by either opening the phone or by pressing a key. This “by keypress” answering option allows you to decide whether or not to answer a call based on incoming caller ID information on the screen. Possible settings: “by keypress” “by opening.”
- 2 Auto Retry Set the length of time the phone waits before automatically redialing a number when the system is busy. Possible settings:

“every 60 seconds,” “every 30 seconds,” “every 10 seconds,” “off.”

3 Scratch Pad Store phone numbers during a call. These numbers are added to call history.

4 Mute Switch the microphone on and off while in a call. When the microphone is off, the other party can not hear you.

5 Key Beep Set key beep length and touch tone playback speed. Possible settings: “long,” “normal.”

6 One-touch Enable/disable one-touch phone book memory dialing. Possible settings: “enable,” “disable.”

7 Privacy Set the voice privacy feature for CDMA calls. Possible settings: “enhanced,” “standard.”

CDMA offers inherent voice privacy. Check with your service provider for availability of the enhanced voice privacy mode. During a call, if active, you will see an inverse “P” on the same line as the call time.

8 Ringer Types Set the sound that the phone will make when a call comes in. Possible settings: “standard,” options 1 to 4.

6 Display

This allows you to choose what you see on the display.

- 1 Backlight Choose the setting of the LCD and keypad backlighting. Possible settings: “on,” “when open,” “always off,” “10 seconds,” “30 seconds.” “10 seconds” turns the backlight off 10 seconds after the last key was pressed. “30 seconds” waits 30 seconds after the last key press. “When open” means that the backlight is on when the phone is open. “Always off” means that the backlight is never on.
- 2 Banner A banner enables you to personalize your phone by displaying your name, for example. Enter the banner (up to 12 characters) that will display on the top line when the phone powers up and when it is in standby. Press the key under [EDIT] to make changes to the existing banner. Enter the characters the same way you do for the phone book.
- 3 Show Time Choose whether to display date and time. Possible settings: “yes,” “no.”
- 4 Auto Hyphen Possible settings: “on,” “off.” When on, automatically inserts hyphens to be consistent with U.S. phone numbers.

7 Alerts



- | | |
|-----------|---|
| 1 Fade | Set an alert to inform you when you have lost a call or lose service. Possible settings: “on,” “off.” |
| 2 Minute | Set minute minder to beep every 10 seconds before the minute while in a call. |
| 3 Service | Set an alert to beep when a network service parameter changes. |

8 System

This allows you to set some of the PCS network settings.

- | | |
|--------------|--|
| 1 Set NAM | Select the phone’s NAM (Number Assignment Module) if the phone is registered with multiple service providers. |
| 2 Auto NAM | Allows the phone to automatically switch to one of the programmed NAMs if it is operating in the corresponding service provider area. |
| 3 Activation | If supported by your service provider, this item enables you to initiate over-the-air activation in order to get your phone working through a few key presses. |

PAGING, MESSAGING, AND VOICE MAIL

This feature allows your phone to receive messages when it is turned on. A single key, , allows you to access your messages while a four line display provides for easy viewing. While reading a message, you can return a call to the callback number provided in the message simply by pressing   twice.

Messages are stored in the phone's memory and are not erased when the phone is turned off. The phone has the capability of storing up to 23, 40 character messages. However, the number of messages that can be stored will be reduced if messages are greater than 40 characters.

Note

Check with your service provider regarding the availability of this feature. The information contained in a message, such as time stamp and callback number, depends on the mode the phone is operating in and the service provider's network capabilities.



This phone supports three types of messages:

Message	typically contains text
Page	typically contains digits

Voice Mail Notification

indicates the number of new voice mail messages that your voice mailbox has. You must call your voice mail number to listen to these messages.

New Message Alert

The phone will notify you of a new message by a display on the screen, five short beeps (if enabled), a flashing red light on the earpiece, and by turning on the  icon on the top of the display. If a message is marked URGENT, the  icon will flash. In addition, the first line of the display will contain asterisks (*) on each side of the label for example, “* MESSAGE! *”.

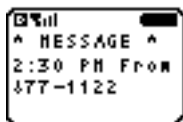





The phone will then be returned to the display that was present before the alert. The red light will continue to flash and a reminder beep will occur every two minutes until the new message is acknowledged.

Viewing Pages and Messages

These messages may consist of a time stamp, a callback number, a name (if the callback number matches a phone number stored in a memory location), and text. They are accessed as text type messages as shown below.

Reading New Messages



1. Press . The display will then show the number of new messages.
2. Press the  key under [TEXT]. You will see the messages in the order they were received except for all urgent messages, which will be displayed first.

Messages will automatically scroll page by page. To manually scroll through the message line by line, press  or . At the end of the message, the Smart Key options will be [ERASE] and [NEXT].

3. Press the  key under [ERASE] to erase the message and go to the next message.

or

Press the  key under [NEXT] to keep the message in memory and go to the next message.



4. Press  to view the callback number provided in the message.
5. Press  again to place a call to the callback number.

Note





When there are no new messages, the phone will display a list of previous messages.

If the callback number has not been previously stored into one of the phone's memory locations, you can do so by pressing the  key under [SAVE].

If a name appears with the callback number, the number is already stored in a phone memory location.

After storing the number in phone book memory, the phone returns to the callback screen. Press  to place the call. You may prepend digits, such as an area code, simply by pressing the desired digits before pressing .

Reading Previous Messages

1. Press .
2. Press the  key under [TEXT]. This displays the list of previous messages. Each line will show the first 11 characters of the messages.
3. Press  or  to select the message.
4. Press the  key under [ERASE]. This erases the message and goes to the next message.

or

Press the  key under [VIEW]. This lets you view the message.

5. While viewing a message or with the arrow pointing to the desired message, you can press





SEND/TALK to place a call to the callback number provided in the message. After you see the callback number on the display, press **SEND/TALK** again to place the call.

6. Press the  key under [QUIT]. This brings you back to the list of previous messages.

Voice Mail Notifications

Voice mail notification indicates the number of new voice mail messages in your mailbox. Only the most recent voice mail notification will be stored in the phone; previous messages will be overwritten. You must call your voice mail service to retrieve these messages.

Reading Voice Mail Notification Messages

1. Press .
2. Press the  key under [VOICE] to view the entire message. The phone will automatically scroll page by page. To manually scroll, press  or .
3. Press **SEND/TALK** to call back your voice mailbox if your voice mail system has sent a callback number.

or

Press the  key under [QUIT] when you get to the end of the message.

or

Press the key under [ERASE] to erase the message and turn the icon off. Usually, this is not required because the network will command the phone to automatically turn the icon off when you have no new messages.

Low Memory Warning

The phone will alert you when the amount of available message memory is less than 25%. Although the phone can still receive new messages, you should erase messages you no longer need to avoid running out of memory.

Out of Memory Warning

When the phone has no more available message memory, it can no longer accept new messages. When this occurs, the phone will display an “Out of Memory” message.

ACCESSORIES

You can purchase a number of accessories for your Q Phone, including batteries, chargers, and a hands-free car kit. For our full line of accessories, visit our Accessories Store at

- www.kyocera-wireless.com/store

Or order by phone at

- (800) 211-1537 or (510) 683-4004

PHONE SAFETY AND CARE

Background

The hand-held portable telephone is one of the most exciting and innovative electronic products ever developed. It let's you stay in touch wherever you go.

Your telephone is a radio transmitter and receiver. When it is ON, it receives and also sends out radio frequency (RF) energy. When you use your phone, the system handling your call controls the power level at which your phone transmits. The power level can range from 0.006 of a watt to 0.2 of a watt.

Exposure to Radio Frequency Energy

In August 1996, the Federal Communications Commissions (FCC) adopted RF exposure guidelines with safety levels for hand-held wireless phones. Those guidelines are consistent with the safety standards previously set by both U.S. and international standards bodies:

ANSI C95.1 (1992) American National Standards Institute, NCRP Report 86 (1986) National Council on Radiation Protection and Measurements, ICNIRP (1996) International Commission on Non-Ionizing Radiation Protection.

The design of your phone complies with the FCC guidelines (and those standards).

For Best Performance

To properly operate the phone and maintain safe and satisfactory service, follow these rules:

- Extend the antenna fully.
- Hold the phone with the antenna up and over your shoulder.
- Do not hold the phone antenna at any time. Contact with the antenna affects call quality and may cause the phone to operate at a higher power level than otherwise needed.
- Do not use the phone with a damaged antenna.
- Speak directly into the mouth piece.
- Use the phone when the car is stopped.

Avoid exposing the phone and accessories to rain or liquid spills. If the phone gets wet, turn the power off immediately and remove the battery pack. If the phone is inoperable, then return it to the dealer for service.

Only authorized personnel should install or service the phone and its accessories. Faulty installation or service may be dangerous and may invalidate the warranty.

Antenna Care

Use only the supplied or an approved replacement antenna. Unauthorized antennas, modifications, or attachments, could damage the phone and may violate FCC regulations.

Caring for the Battery

For best battery performance, follow these guidelines:

- Only use Kyocera battery packs, model numbers TABAT0201 or TABAT0202, and Kyocera chargers, model numbers TADTC0201 or TATVL0201. Do not use any other battery pack or charger. Kyocera's chargers are designed to maximize the battery life performance.
- Do not charge the battery pack in temperatures outside of 32°F to 122°F (0°C to 50°C) because damage could occur.
- Do not use the battery charger in direct sunlight or in places with high humidity such as the bathroom.
- Never dispose of the battery pack by a fire.
- Keep the metal contacts at the top end of the battery pack clean.
- Do not attempt to disassemble or short circuit the battery pack.
- You may need to recharge the battery if it has not been used for a long time.
- Replace the battery when it no longer provides acceptable performance. The battery pack may be recharged hundreds of times before it will need to be replaced.
- Do not store the battery pack for long periods in places where high temperatures frequently occur. Follow these storage rules:

less than 1 month: -4°F to 140°F (-20°C to 60°C)

more than 1 month: -4°F to 113°F (-20°C to 45°C)

Driving Safety

Talking on the phone while driving is extremely dangerous and is illegal in some states. Remember, safety comes first.

Check the laws and regulations on the use of PCS phones in the areas where you drive. Always obey them.

Also, if using your phone while driving, please:

- Give full attention to driving. Driving safety is your first responsibility.
- Use hands-free operation, if available.
- Pull off the road and park before making or answering a call if driving conditions require.

If you must use the phone while driving, please use one-touch, speed dialing, and auto answer modes.

For vehicles equipped with an air bag: An air bag inflates with great force. DO NOT place objects, including both installed or portable wireless equipment, in the area over the air bag or in the air bag deployment area. If in vehicle wireless equipment is improperly installed and the air bag inflates, serious injury could result.

**FAILURE TO FOLLOW THESE INSTRUCTIONS
MAY LEAD TO SERIOUS PERSONAL INJURY
AND POSSIBLE PROPERTY DAMAGE.**

Other Safety Guidelines

Electronic Devices

Most modern electronic equipment is shielded from RF energy. However, certain electronic equipment may not be shielded against the RF signals from your wireless phone.

Pacemakers. The Health Industry Manufacturers Association recommends that a minimum separation of six (6") inches be maintained between a handheld wireless phone and a pacemaker to avoid potential interference with the pacemaker. These recommendations are consistent with the independent research by and recommendations of Wireless Technology Research. **Persons with pacemakers:**

- Should always keep the phone more than six inches from their pacemaker when the phone is turned ON.
- Should not carry the phone in a breast pocket.
- Should use the ear opposite the pacemaker to minimize the potential for interference.
- If you have any reason to suspect that interference is taking place, turn your phone OFF immediately.

Hearing Aids. Some digital wireless phones may interfere with some hearing aids. In the event of such interference, you may want to consult your service provider (or call the customer service line to discuss alternatives.)

Other Medical Devices. If you use any other personal medical device, consult the manufacturer

of your device to determine if they are adequately shielded from external RF energy. Your physician may be able to assist you in obtaining this information.

Turn your phone OFF in health care facilities when any regulations posted in these areas instruct you to do so. Hospitals or health care facilities may be using equipment that could be sensitive to external RF energy.

Vehicles

RF Signals may affect improperly installed or inadequately shielded electronic systems in motor vehicles. Check with the manufacturer or its representative regarding your vehicle. You should also consult the manufacturer of any equipment that has been added to your vehicle.

Posted Facilities

Turn your phone OFF in any facility where posted notices so require.

Aircraft

FCC regulations prohibit using your phone while the plane is in the air. Switch OFF your phone before boarding an aircraft.

Blasting Areas

To avoid interfering with blasting operations, turn your phone OFF when in a “blasting area” or in areas posted: “Turn off two-way radio.” Obey all signs and instructions.

Potentially Explosive Atmospheres

Turn your phone OFF when in any area with a potentially explosive atmosphere and obey all signs and instructions. Sparks in such areas could cause an explosion or fire resulting in bodily injury or even death.

Areas with a potentially explosive atmosphere are often, but not always, clearly marked. They include fueling areas such as gas stations; below deck on boats; fuel or chemical transfer or storage facilities; vehicles using liquefied petroleum gas (such as propane or butane); areas where the air contains chemicals or particles, such as grain, dust, or metal powders; and any other area where you would normally be advised to turn off your vehicle engine.

WHERE TO FIND HELP

Your Service Provider

For questions about your phone and phone service, contact your service provider first. Your service provider's customer support department can answer questions about your phone, phone bill, call coverage area, and specific features (such as call forwarding or voice mail) available to you.

Your Phone Documentation

If you have questions about the features of the phone, refer to this guide and other materials provided with your phone. To view or download the most current version of this user's guide, visit us at www.kyocera-wireless.com.

Kyocera Technical Support

If you have additional questions, contact the Kyocera Wireless Customer Care Center in any of these ways:

- Website: www.kyocera-wireless.com
- U.S. and Canada: (800) 349-4478
- Other Countries: (858) 882-1400
- Email: phone-help@kyocera-wireless.com

Before requesting support, please try to reproduce and isolate the problem. When you contact support, be ready to provide the following information:

- The name of your service provider
- The actual error message or problem you are experiencing
- The steps you take to reproduce the problem
- The Electronic Serial Number (ESN) and Part Number (MCN) of the phone. The ESN usually starts with a "B" and the MCN usually starts with a "61-." You will find these numbers inside the battery cover of your phone.

INDEX

A

- AC adaptor 14**
- accessories 6, 47**
- aircraft 51**
- alerts 38**
 - fade 38**
 - minute 38**
 - service 38**
 - setting 38**
- answering a call 7, 49**
- Antenna 9, 13**
- antenna 20, 47**
- Auto NAM 38**
- automatic hyphenation 37**
- automatic redial 6, 35**
- automatic retry 35**
- automatic scrolling 41, 43**

B

- backlight 37**
- banner 37**
- battery**
 - care 48**
 - charge 20**
 - charging 13, 14**
 - installing 11**
 - level indicator 10, 14**
 - use 11**
- best performance 20, 47**
- blasting areas 51**

C

call history 18, 21, 25, 30, 35, 36

call info 33

call waiting 9, 17

calls

 credit card 28

 dialing 27, 28, 35

 ending 9

 incoming 9, 17, 21, 34

 making 16, 19, 49

 receiving 17

 redialing 18, 35

 restrictions 35

 roaming 10, 34

 three-way 9, 17

car kit 12

CDMA 6, 36

cigarette lighter adaptor 12, 14

clear

 calls 35

clear digits 15

Code Division Multiple Access 6, 36

correcting dialing mistakes 16

D

dialing calls 18, 27, 36

dialing from memory location 28

digital system 10

display 6

display features 20, 26, 37

display indicators 10, 16

driving safety 49

E

earpiece 17, 18, 32, 33

editing 29

 memory 26

- numbers 19
- emergency numbers 18, 19, 34, 35
- END key 9
- ending a call 9
- entering
 - a number 16, 22, 24, 28, 35
 - letters 24
 - lock code 19, 34, 35
 - lower case letters 30
 - name 22
 - punctuation 29
- explosive atmospheres 52

F

- fade alert 38
- features 6, 9, 18, 21, 28, 31, 35
- frequency 46
- Functions 15
- functions 15, 18

I

- incoming calls 9, 21, 34

K

- key beep volume 33
- keypad lock 6, 7

L

- last ten numbers dialed 18, 25
- lock code 34, 35
- low battery 14

M

- manual pauses 28
- memory
 - clearing 26
 - editing 26

- effect 14
- locations 6, 21, 24, 25, 27, 30
- storage 39
- menu
 - item descriptions 32–54
 - method 31
 - options 31
 - shortcuts 32
- message
 - text 10
- message key 9
- messages 39–54
- minute alert 38
- mute 36
- muting voice 36

N

- NAM 38
- no service 10
- Number Assignment Module 38

O

- one-touch dialing 27, 36
- own phone number 16

P

- pages 10
- pause dialing 28
- performance tips 47
- phone book 21
 - advanced features 28
 - dialing from 27, 36
 - editing 26
 - saving numbers to 22
- phone number
 - viewing your own 16
- power 46

POWER key 9
power key 9
power save mode 20
powering off 12
powering on 12

R

radio frequency energy exposure 46
recalling last number dialed 18
recalling previously dialed numbers 25
Receive Signal Strength Indicator 10, 19
receiving calls 9, 17
receiving messages 40
red light 14, 40
redial 18
 system busy timer 35
review last number dialed 18
ringer volume 18, 32
RSSI 10, 19

S

safety 49, 50
scratch pad 21, 36
scroll
 through messages 43
 through stored names 24
 through stored numbers 25
scroll keys 9
searching
 for names 24
 for numbers 24, 25
secret numbers 30
signal strength 10, 19
Smart Keys 9, 15
speed dial 6, 27, 49
standby time 11
storing
 names with numbers 22

numbers 19, 22–23
secret numbers 30

T

talk time 11

timer

last call 33. *See also* call info

roaming 34. *See also* call info

total 34. *See also* call info

travel charger 14

V

voice mail 9, 43

volume

earpiece 18, 33

key beep 33

keys 9

ringer 18, 32